

## Technical Specifications - FORGED STEEL LIFT CHECK TYPE NON RETURN VALVE (800)

|   |  |
|---|--|
| <p><b>Type of Valve</b></p> <p><b>Materials of Construction:</b></p> <p>a. Body &amp; Cover</p> <p>b. Disc</p> <p>c. Body Seat-Ring</p> <p>d. Gasket</p> <p>e. Bolts &amp; Nuts</p> <p><b>Design</b></p> <p><b>Dimension</b></p> <ul style="list-style-type: none"> <li>• Flange To Flange</li> <li>• Ends</li> </ul> <p><b>Hydraulic test pressure:</b></p> <ul style="list-style-type: none"> <li>• Body</li> <li>• Seat</li> </ul> <p><b>Range</b></p> | <p>Lift Check Non Return Type, Bolted Cover, Renewable Body Seat-Ring and Integral Disc Face Ring</p> <p>FS to ASTM A 105<br/>AISI 410<br/>13% Cr. Steel<br/>CAF<br/>ASTM A 193 Gr. B7/A 194 Gr. 2 H</p> <p>API 602 Class 800</p> <p>API 602 Class 800<br/>Socket Weld as per ANSI B 16.11 / Screwed To ANSI B 2.1 / IS 554 Parallel Thread</p> <p>211 Kg/Cm<sup>2</sup><br/>140 Kg/Cm<sup>2</sup></p> <p>15 mm NB to 40 mm NB</p> |
|---|--|

**Part Name:**

1. Body
2. Cover
3. Disc
4. Body Seat-Ring
5. Gasket
6. Studs & Nuts

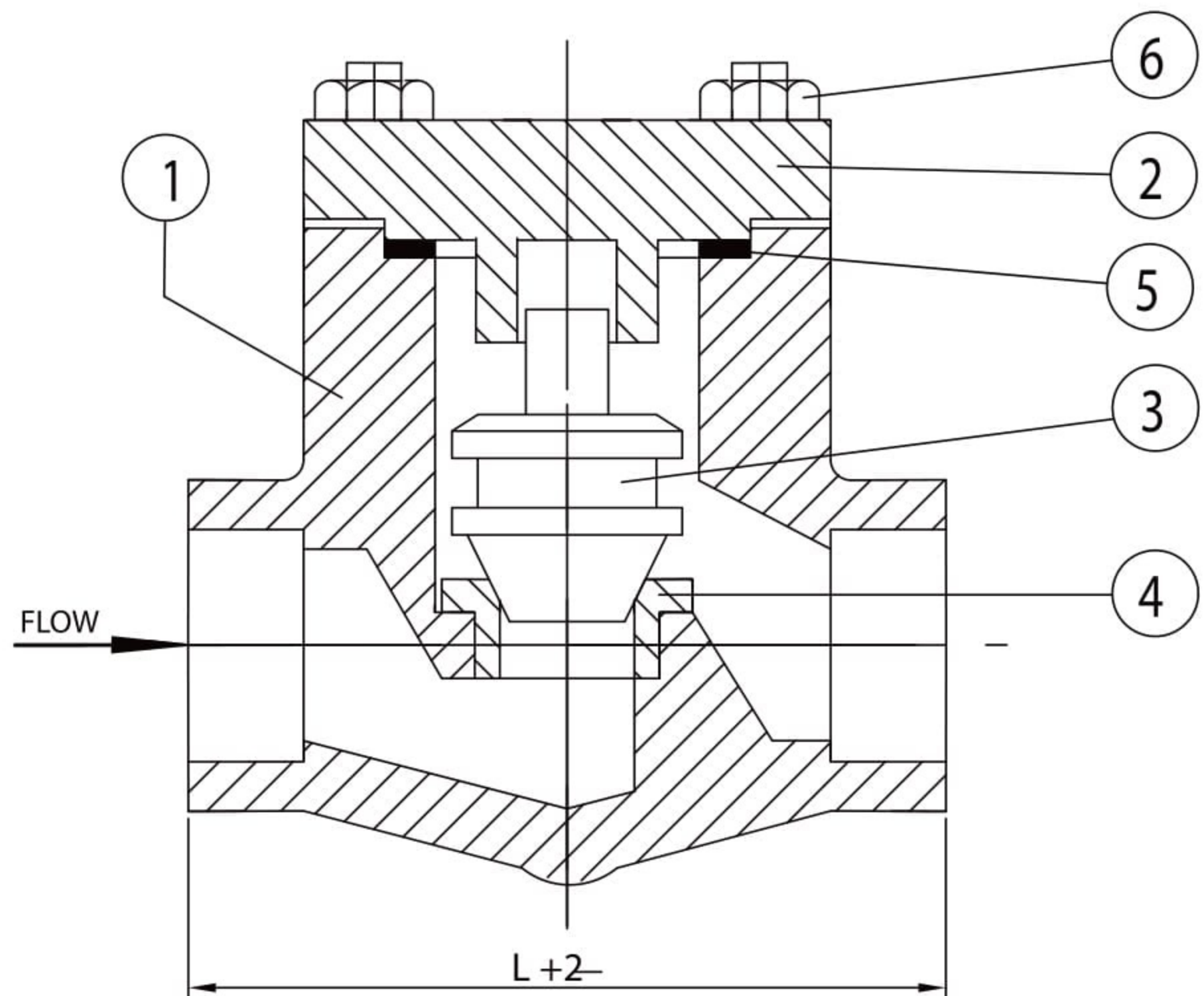

- Note**
- Description given is generalized, may vary as per requirement.
  - Specifications given above are subject to change as per revisions in standards without notice.
  - Quotations are based on customer's requirement and data. Customers are requested to send specific requirement for an offer.
  - All sizes in millimeter

**H. Sarker & Company Valves (P) Ltd.**

**Works:** Phone: +91 33 2653 1214 / 0061 • eMail: hsb1t09@gmail.com  
**Regd. Office:** Ajit Sen Bhawan, 13 Crooked Lane, 2nd Floor, Kolkatta 700 069.  
 Phone: 033-22109163

